



model 1107LHO

Wall Mount ADA Touchless Fountain

FEATURES & BENEFITS

CONSTRUCTION

One-piece drinking fountain with low-profile design made of 14 gauge Type 304 stainless steel with 1/4" (.6 cm) thick stainless back plate welded in, and vandal-resistant stainless bottom plate. Satin finish resists stains and corrosion.

QUALITY CONTROL

Pre-built fountain is pressure tested to ensure no leaks and proper functionality.

ACCESS

Low profile designed bowl and integral trap allow for knee clearance for adult or child ADA access (when installed at appropriate heights).

BUBBLER HEAD

Polished chrome-plated brass bubbler head with integral 11/16" dia. basin shank and stainless anti-rotation roll pin for vandal resistance strength. Shielded, angled stream opening provides a steady, sanitary source of drinking water at .45 gpm.

FOUNTAIN VALVE

Fountain incorporates a touchless sensor operated stainless steel solenoid valve controlled by a transformer for handsfree operation. A pressure regulator is used to adjust the bubbler flow according to incoming water pressures.

INTEGRATED TRAP

All cast brass 1-1/4" NPT adjustable trap completely concealed inside bottom plate for easy installation and access.

TAMPER RESISTANT

30-second obstruction time-out to reduce tampering of sensor.



SPECIFICATIONS

Model 1107LHO low profile ADA wall mounted touchless drinking fountain shall include an 14 gauge Type 304 Stainless Steel satin finish basin, touchless sensor operated stainless steel solenoid valve with 30-second obstruction time-out controlled by a transformer, 100% lead-free waterways, polished chrome-plated brass vandal-resistant bubbler head, polished chrome-plated brass vandal-resistant waste strainer, vandal-resistant bottom plate, and 1-1/4" NPT trap.

FOR INDOOR USE ONLY

APPLICATIONS

Perfect for either public or private indoor settings, the 1107LHO is a great fit in areas where aesthetics are important to the overall appeal of the architecture. Beautiful satin finish helps to maintain the fountains overall appeal. Specifically, this type of wall mounted drinking fountain may be placed in settings such as: schools and other locations in and around office buildings. Model meets all current Federal Regulations for the disabled including those in the Americans with Disabilities Act. Haws manufactures drinking fountains and electric water coolers to be lead-free by all known definitions including NSF/ANSI Standard 61, Section 9, NSF/ANSI 372, California Proposition 65, and the Federal Safe Drinking Water Act. Product is compliant to California Health and Safety Code 116875 (AB 1953-2006).

OPTIONS

- ❑ Remote Drinking Fountain Water chiller: Model HCR8, 8 gph (30.3 L) remote water chiller provides instantaneous cooling to meet a continuous demand for chilled water.
- ❑ Bottle Filler: Model 1920HO stand-alone bottle filling station, or mounted above Haws 1001, 1011, 1107L, 1109, 1117L, and 1119 series drinking fountain models.
- ❑ Mounting Plate: Model 6700 universal mounting plate for most wall mounted fountains.
- ❑ Support Frame: Model 6800 In-wall floor mounted fixture support legs, welded steel 4-bolt floor flanges, and supplied with 'U' bolts and hardware.

For more information, visit www.hawsc.com or call (888) 640-4297.



NOTES:

1. HOLD ROUGH-IN DIMENSIONS ± 1/4" (6.4mm)
2. WHEN INSTALLING THIS UNIT, LOCAL, STATE OR FEDERAL CODES SHOULD BE ADHERED TO. FOR INSTALLATION HEIGHTS OTHER THAN SHOWN, DIMENSIONS MARKED (*) MUST BE ADJUSTED ACCORDINGLY.
3. REFER TO 5874 SERIES OPERATION AND MAINTENANCE MANUAL FOR PUSH BUTTON AND VALVE INSTALLATION AND MAINTENANCE INSTRUCTIONS.
4. ROUGH IN DIMENSIONS FOR FOUNTAIN HEIGHTS:

CHILD WHEELCHAIR HEIGHT: SEE SHT 2 FIG 1
 WASTE: 26-1/4" (667mm)
 SUPPLY: 26-1/8" (664mm)
 MOUNTING HOLE: 24-13/16" (630mm)
 MOUNTING PLATE: 23-3/16" (589mm)
 FOUNTAIN: 24" (610mm)
 BUBBLER: 29-7/8" (756mm)

ADULT WHEELCHAIR HEIGHT: SEE SHT 2 FIG 2
 WASTE: 29-1/4" (743mm)
 SUPPLY: 29-1/8" (740mm)
 MOUNTING HOLE: 27-13/16" (706mm)
 MOUNTING PLATE: 26-3/16" (665mm)
 FOUNTAIN: 27" (686mm)
 BUBBLER: 32-7/8" (832mm)

STANDING ADULT HEIGHT: SEE SHT 2 FIG 3

WASTE: 34-3/4" (883mm)
 SUPPLY: 34-5/8" (879mm)
 MOUNTING HOLE: 33-5/16" (846mm)
 MOUNTING PLATE: 31-1/16" (805mm)
 FOUNTAIN: 32-1/5" (826mm)
 BUBBLER: 38-3/8" (972mm)

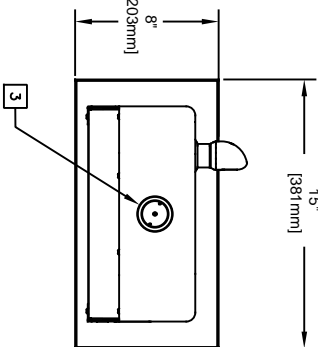

Available with hands off sensor
 in lieu of push button valve.

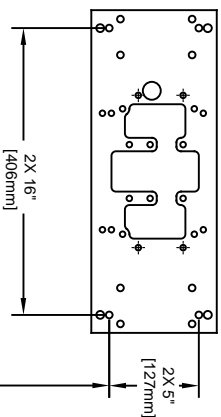
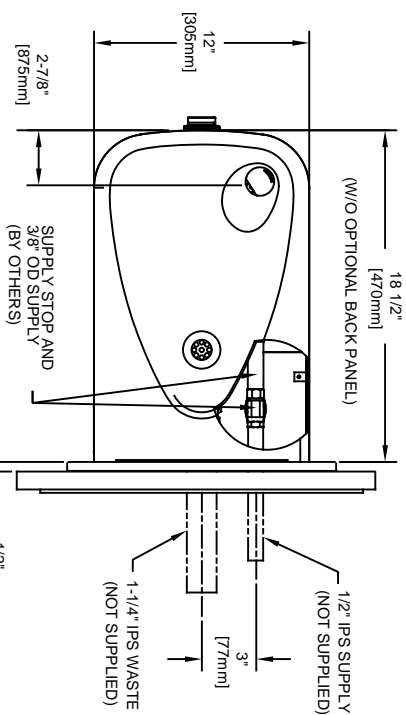

CHILD/ADULT/
 ADULT STANDING
 MOUNTING PLATE

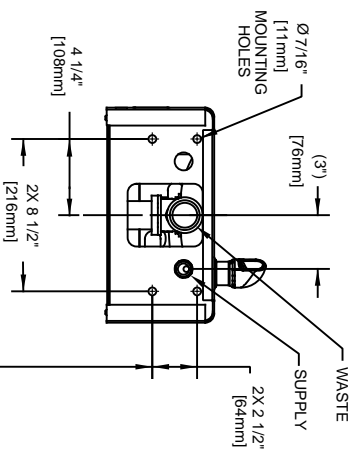

CHILD/ADULT/
 ADULT STANDING
 MOUNTING HOLE

MOUNTING DETAIL
 BACK VIEW

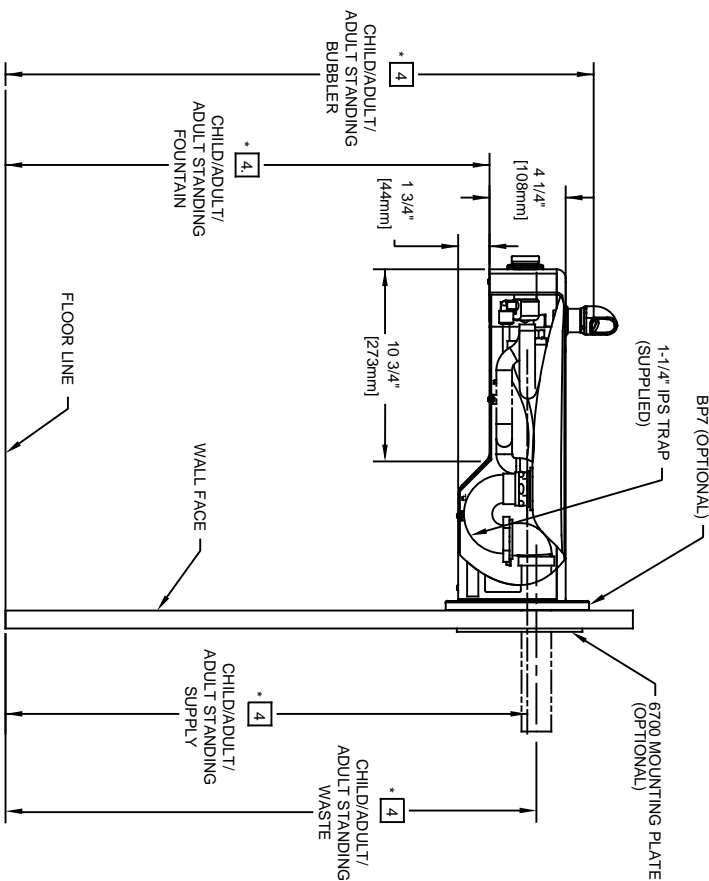

CHILD/ADULT/
 ADULT STANDING
 SUPPLY

CHILD/ADULT/
 ADULT STANDING
 WASTE



Haws

1456 KLEPPE LANE
 SPARKS, NEVADA, 89431
 (775) 359-4712 FAX (775) 359-7424
 E-MAIL: HAWS@HAWS.CO.COM
 WEBSITE: WWW.HAWS.CO.COM

ECN NO.	REVISED PER BY:	MODEL(S)	PART NUMBER
DRAWN:	DATE:		0002080232.D
CHECKED:	CHKD:		REVISION
APPROVED:	DATE:		15
SCALE:	DRAWING TYPE:	INSTALLATION	SHEET 1 OF 1